

## Fuel Inspection Systems

### Description

DEI offers inspection equipment that is designed to be integrated with its HE-UFC™ and BNDE™ ultrasonic fuel cleaning systems so that the condition of the fuel can be assessed in parallel with the cleaning activity (with no added time). This includes systems that obtain high-resolution images and video of the fuel bundle bottom nozzle and the full length of all four faces before, during and after the cleaning activity. This facilitates an assessment of whether crud or debris is present, and confirmation of removal during the cleaning activity.

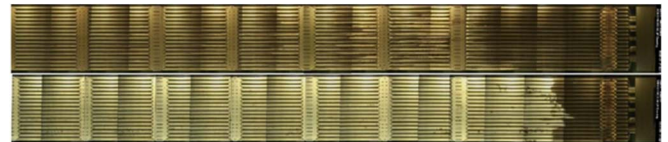
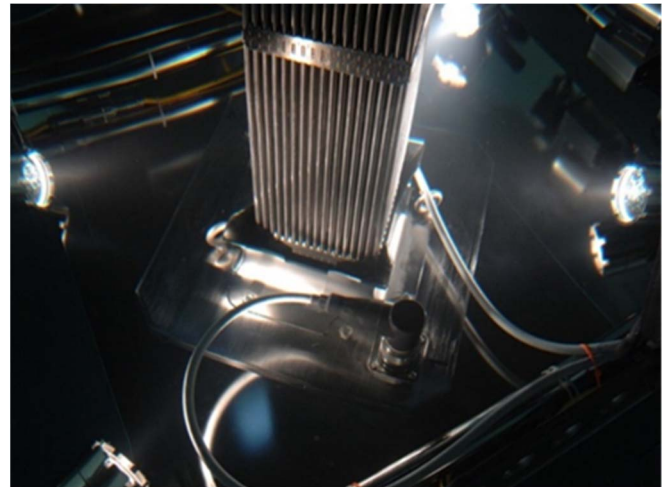

Full length cleaning & inspection  
(with images shown before / after HE-UFC™)

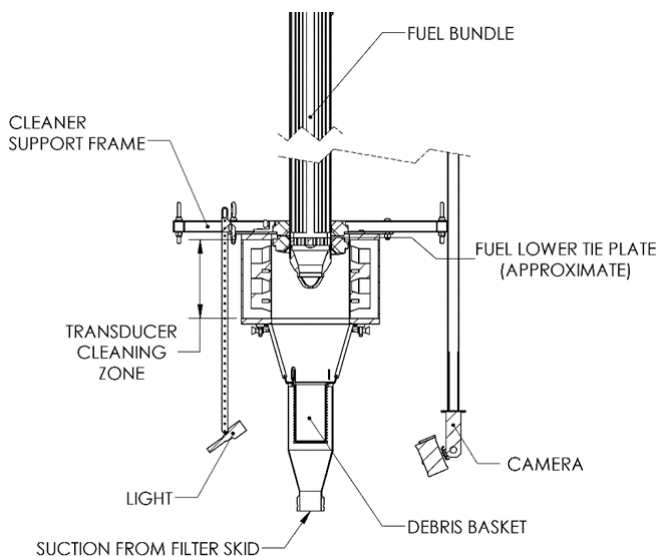
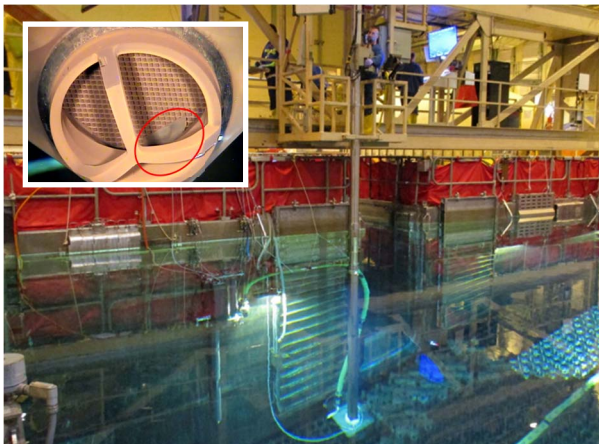

Bottom nozzle cleaning & inspection

### Features and Benefits

- Identifies whether potentially harmful debris is present in the fuel bundle bottom nozzle, and confirms removal of crud and debris
- Fuel inspection completed in parallel with cleaning (no added time to assess condition of fuel bundles before and after cleaning)
- Generates high resolution images and video of bottom nozzle & all four faces (full length)

### Industry Experience

- >200 HE-UFC™ and BNDE™ fuel cleaning campaigns have been completed to date in 5 countries
- Many of these campaigns have incorporated DEI fuel inspection systems such that fuel inspections could be completed in parallel with fuel cleaning activities

For more information, contact Mike Little ([mittle@domeng.com](mailto:mittle@domeng.com)), or David Arguelles ([darguelles@domeng.com](mailto:darguelles@domeng.com))